

Titan Hydraulic Motor™

P1A Series

TITAN MOTOR / PLANETARY
TORQUE MULTIPLIER COMBINATION
GEAR RATIO = 5.5:1 (NOMINAL)

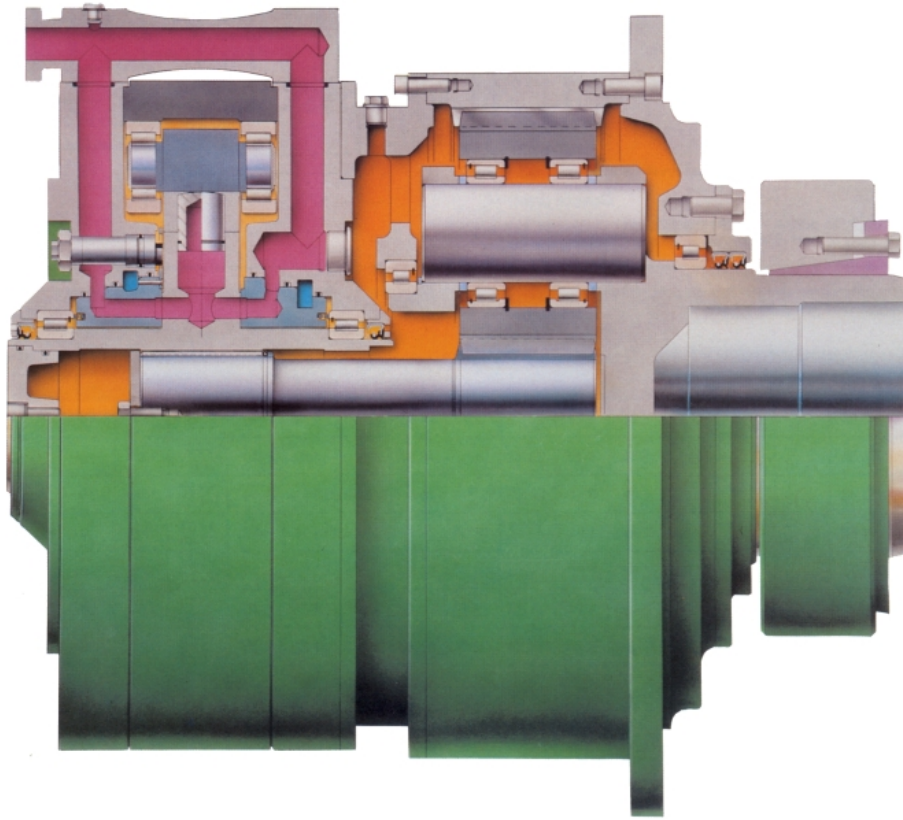

FEATURES:

- SHAFT MOUNTED - NO FOUNDATIONS, BEDPLATES OR ALIGNMENT CONCERNS
- EXTREMELY COMPACT
- VERY FAVORABLE WEIGHT / TORQUE RATIO
- EXCELLENT LOW SPEED CAPABILITY
- SUPERIOR SERVICE LIFE
- EXCEPTIONALLY QUIET RUNNING
- COMPETITIVELY PRICED
- VERY LOW MASS MOMENT OF INERTIA
- OUTPUT TORQUE CAPACITY UP TO 1'800.000 Nm. INTERMITTENTLY; 1'400.000 Nm CONTINUOUSLY
- WIDE RANGE OF ACCESSORIES

OPTIONS:

- DOUBLE REDUCTION WITH NOMINAL RATIOS TO 40:1
- FLANGE MOUNTED WITH SOLID OUTPUT SHAFT
- FOOT MOUNTED WITH SOLID OUTPUT SHAFT

ACCESSORIES:

- THRUST BEARINGS
- ENCODERS
- TORQUE ARMS
- POWER UNITS and CONTROL SYSTEMS
- MULT-DISC BRAKES
- BACKSTOPS
- CROSS-LINE RELIEF VALVES

R & L POWER SYSTEMS

1019 LIBRA PLACE
BILLINGS, MT 59105 USA

Telephone: +1 (406) 839 - 1211
Telefax: +1 (832) 565 - 1853
Email: sales@randpowersystems.com

TITAN™ Motor • Single Stage Gear Drive • Shaft Mounted • Hollow Shaft with Shrink Disc Connection ⁽¹⁾

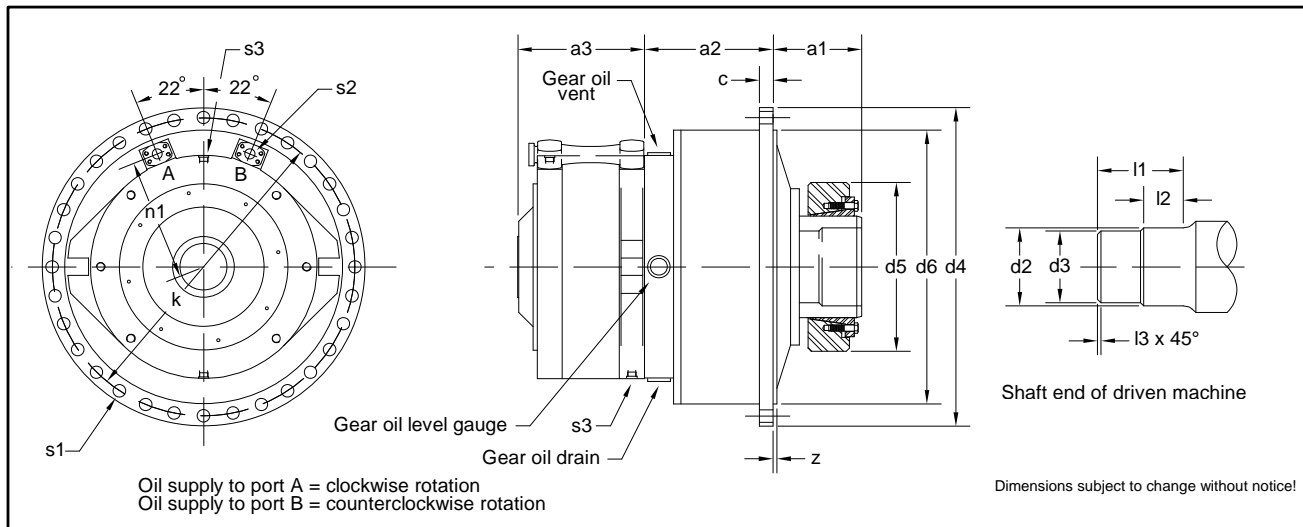

Dimensions (mm)

Type HMD	Planetary Torque Multiplier Type P1A	a1	a2	a3	c	d2 h6	d3 h6	d4	d5	d6 h6	k	l1	l2	l3	n1	s1	Qty.	s2 SAE Flange	s3 Motor Drain Ports	Z
410	112	165	296	250	20	150	145	510	360	380	470	165	80	2.5	231	22	16	1"	G ¾	7
410	125	185	300	250	23	160	155	590	370	430	540	185	90	2.5	231	26	16	1"	G ¾	7
515	140	198	349	311	25	180	175	630	405	470	580	195	95	2.5	294	26	18	1½"	G ¾	9
515	150	198	320	311	28	190	185	700	405	530	650	195	95	2.5	294	26	24	1½"	G ¾	9
635	170	213	385	379	32	200	195	760	430	590	710	205	100	2.5	365	26	30	1½"	G 1	9
635	200	250	416	379	36	240	225	900	520	690	840	225	110	2.5	365	33	24	1½"	G 1	11
745	224	255	459	438	40	260	255	970	570	760	910	245	120	2.5	414	33	30	1½"	G 1	11
745	250	288	494	438	40	280	275	1060	590	830	1000	255	125	2.5	414	33	32	1½"	G 1	11
910	265	288	518	535	46	300	295	1160	660	910	1090	260	127.5	2.5	503	39	28	2"	G 1¼	16
910	280	290	577	535	52	320	315	1280	690	980	1180	275	135	2.5	503	39	32	2"	G 1¼	16
1100	335	348	695	620	62	400	395	1500	850	1180	1410	320	157.5	2.5	600	45	32	2"	G 1¼	18
1100	355	353	745	620	65	420	415	1570	850	1230	1470	345	170	2.5	600	52	32	2"	G 1¼	18
1280	400	450	825	721	75	480	470	1700	960	1460	1600	450	220	5	698	52	32	2"	G 1¼	25
1280	425	465	865	721	80	510	500	1810	1020	1560	1700	480	235	5	698	62	32	2"	G 1¼	30

Displacements, Torques, Pressures, Speed Ranges and Weights

Type HMD	Size P1A	Planetary Torque Multiplier Ratio	Resultant Displacement (cm³ / Rev.)	Torque Ratings (2)		Maximum Pressure (Bar)	Speed Range (RPM)	Maximum Speed (RPM)	Weight (Kg.)	(4) Gear Oil Quantity (Liters)
				Nm / Bar	(3) Nominal (Nm)					
410-01310	112	5,438	7125	115	28000	350	0-29	37	565	6
410-01740	125	5,785	10065	160	42000	350	0-26	32	660	8
515-02975	140	5,625	16735	265	57000	350	0-26	32	855	12
515-03860	150	5,438	20990	335	79000	350	0-26	32	980	17
635-05795	170	5,250	30425	485	108000	350	0-26	32	1460	25
635-07480	200	5,438	40675	645	175000	350	0-22	28	1920	35
745-09865	224	5,438	53645	855	226000	350	0-17	21	2500	45
745-11795	250	5,571	65710	1045	292000	350	0-14	18	2800	60
910-17565	265	5,600	98365	1565	370,000	350	0-11	13	4100	75
910-22230	280	5,571	123885	1855	460000	350	0-9	11	4800	95
1100-29940	335	5,600	167665	2670	792000	350	0-8	10	7500	160
1100-38345	355	5,438	208520	3320	900000	350	0-7	9	7645	185
1280-49950	400	5,438	271630	4320	1200000	350	0-6	7	8840	250
1280-60320	425	5,438	328020	5220	1430000	350	0-6	7	10400	300

- (1) Solid output shaft with foot or flange mounting is also available.
- (2) Theoretical Values
- (3) Planetary rating Service Factor 1.0
- (4) The gear oil quantity listed is a guide value only. The exact quantity depends on the oil sight glass.